

# Sulphuric Acid Applications Guide

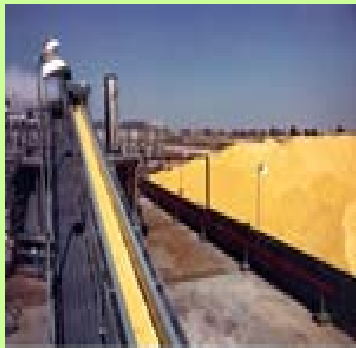

## Sulphur Handling/Melting

**M:** Sulphur (solid, liquid), LP steam  
**P:** Low, medium (3 to 10 bar)  
**T:** Medium (180°C)  
**Apps:** Pipework, injectors, pumps  
**Gasket style:** Soft cut  
**Gasket material:** SF, RGS



## Waste Heat Recovery

**M:** LP, MP, HP\* Steam  
**P:** Low medium (10, 25, 40 bar)  
**T:** 180, 215, 400°C  
**Apps:** Pipework, HX's  
**Gasket style:** Soft cut, SWG  
**Gasket material:** SF, graphite



## Steam Turbine

**M:** HP Steam  
**P:** Medium (40 bar)  
**T: Medium (400°C)**  
**Apps:** Casing, pipework  
**Gasket style:** SWG, Kamm, SC  
**Gasket material:** Graphite, Therm.

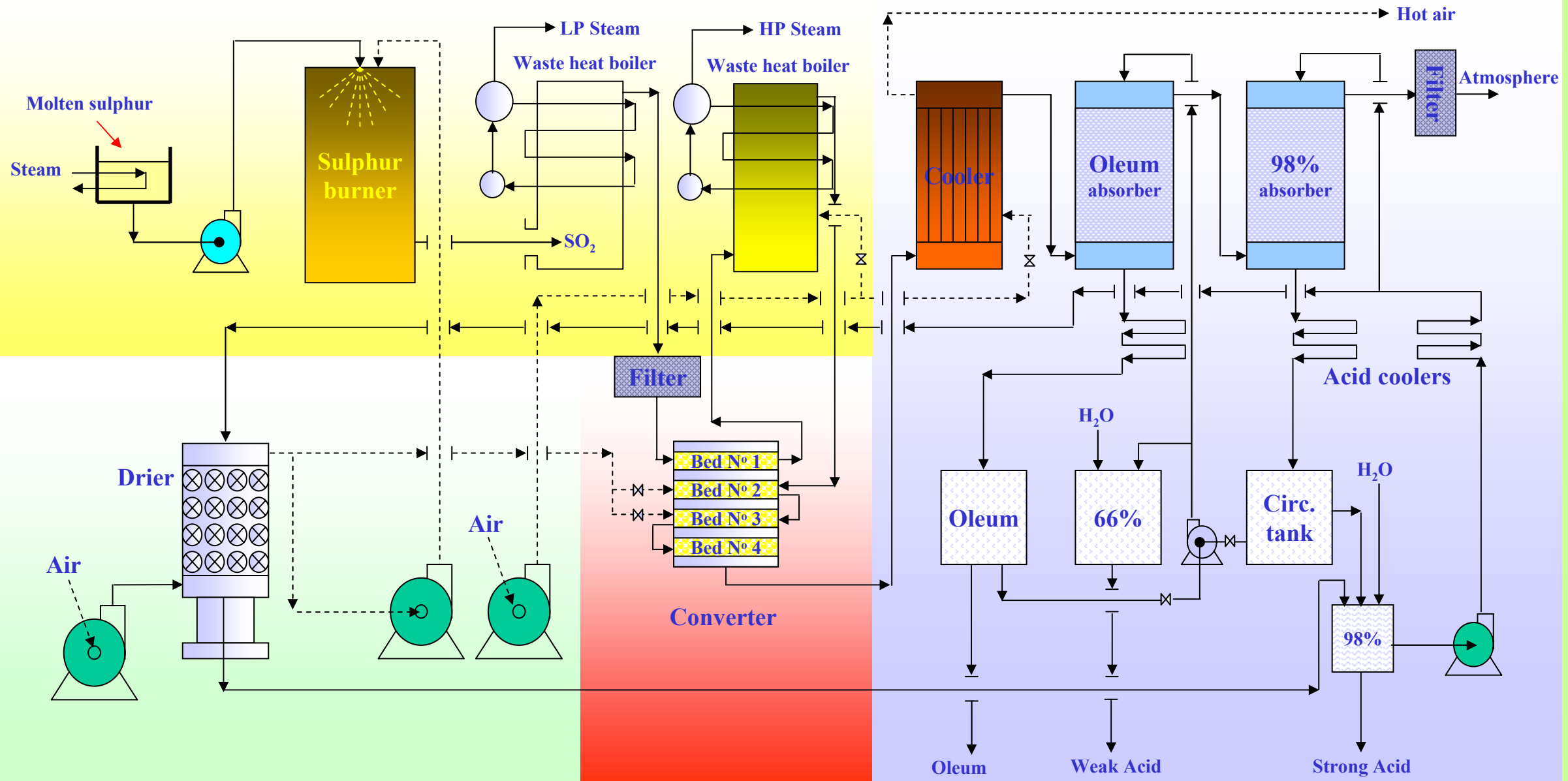

## Drier

**M:** Sulphuric acid (98%), air  
**P:** Low (0.5 bar)  
**T:** Low (125°C)  
**Apps:** Ducting, nozzels  
**Gasket style:** Soft cut  
**Gasket material:** Sigma 500



## Converter

**M:** SO<sub>2</sub>, SO<sub>3</sub>  
**P:** Low (0.5 bar)  
**T:** High 690°C (1<sup>st</sup> pass outlet)  
**Apps:** Ducting  
**Gasket style:** Soft cut  
**Gasket material:** Therm. 815



## Acid Handling/Storage

**M:** Sulphuric acid (66%, 98%, Oleum)  
**P:** Low (3 bar)  
**T:** Low (40°C)  
**Apps:** Tanks, pumps, pipework  
**Gasket style:** Soft cut  
**Gasket material:** Sigma 500



## SERVICES AVAILABLE

- Gasket Design Service
- Stock Analysis & Inventory Management
- FEA
- Drawing Management Services
- Sealing Technology- Education & Training
- Bolted Joint Failure Analysis Report
- Shutdown Management and Emergency Services

**FLEXITALLIC LTD.**

**MARSH WORKS, DEWSBURY ROAD**

**CLECKHEATON**

**WEST YORKSHIRE, BD 19 5BT**

**WWW.FLEXITALLIC.COM**

**TEL: +44(0)1274 851 273**



**SULPHURIC ACID PRODUCTION  
GASKET APPLICATION GUIDE**